

# Installation Guide

## **deltaflow** made by systemec

## 1. Welcome to systemec Controls

Congratulations on your purchase of a deltaflow® dynamic pressure probe, a highly precise measurement tool of superior quality which delivers the best possible results under even the most challenging conditions. In order to take the very best advantage of these qualities, it is important that you install and connect your deltaflow properly. If it is installed incorrectly, even the best tool on the market cannot operate to its full potential. **Please read the Installation and Maintenance Guide carefully and call on our support staff for assistance if any questions arise.** We will be more than happy to review your installation requirements and advise you regarding where and how to install your deltaflow for the best possible results.

## 2. Table of Contents

1. Welcome to systemec Controls.....	2
2. Table of Contents .....	2
3. Selecting an Appropriate Sampling Site .....	3
4. Weld-In Stud Orientation .....	4
4.1. Gaseous Media.....	4
4.2. Liquid Media .....	4
4.3. Steam Media .....	4
5. Installing the Weld-in Stud.....	5
6. Installing the Opposite support.....	6
7. Installing Pulse Conduits / Connecting the Differential Pressure Transducer .....	6
7.1. Steam Media .....	7
7.2. Liquid Media .....	7
7.3. Gas Media .....	8
8. Splitting Range, Bi-directional, or Redundant—Multiple Transmitters for the deltaflow .....	8
9. Zero Point Calibration at Differential Pressure Transducer after Installation .....	9
9.1. Zero Point Calibration for Gas Media.....	9
9.2. Zero Point Calibration for Liquid and Steam Media.....	9
10. Additional Tips for Installing the DF25-Quicklock .....	10
11. Additional Tips for Installing the DF8 / DF10 or DF12/DF25 with spool pieces.....	10
13. Additional Tips for Using the LSP1 Air Flushing System.....	12
14. Integrated Pressure and Temperature Sensors .....	12
15. Iceproofing / Weatherproof Housing .....	13
16. Maintenance .....	13
17. Troubleshooting .....	14
18. Additional Information.....	14
19. Questions?.....	14
20. Flow meters made by systemec.....	15

### Required qualifications of installation / maintenance staff

The installation, commissioning and maintenance of this product have to be done by qualified personnel which has been accepted by the plant operator. The qualified personnel has to read and to understand this manual. Before using deltaflow in corrosive and/or abrasive media the resistance of the material of deltaflow and its components has to be proven by the user or the plant operator. Systemec Controls offers assistance by choosing proper materials but can not assume liability. The user or plant operator has to follow his national regulations for installation, commissioning, service and maintenance.

### Liability regulations

systemec Controls does not assume liability if deltaflow is not used for the intended purpose or if this manual has not been respected or if unqualified personnel have done the required work or if deltaflow or one of its components has changed without written agreement of systemec Controls. The liability will expire in that case.

### 3. Selecting an Appropriate Sampling Site

To reach the optimum degree of precision, the deltaflow needs to be allowed the inlet and outlet path lengths outlined in the table below. The values in the gray shaded fields apply if ImproveIT is used to calculate the adjustment of the measurement values. The fields surrounded by double lines display the standard values.

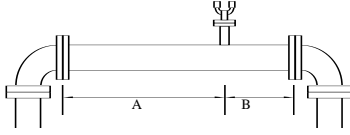
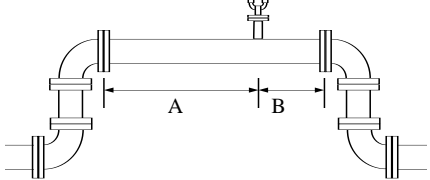
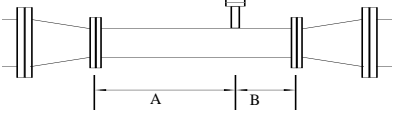
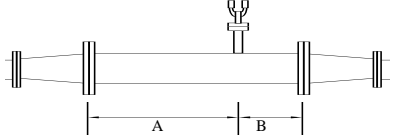
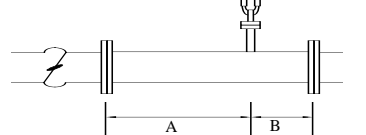
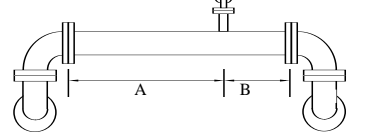
Installation Position	Anticipated Precision Level	Without ImproveIT Adjustment		With ImproveIT Adjustment	
		Inlet A	Outlet B	Inlet A	Outlet B
	0.5%	14 x DI	3 x DI	7 x DI	3 x DI
	<b>1.0%</b>	<b>7 x DI</b>	<b>3 x DI</b>	4 x ID	3 x ID
	2.0 %	4 x DI	2 x DI	1 x DI	2 x DI
	0.5%	18 x DI	3 X DI	7 x DI	3 x DI
	<b>1.0%</b>	<b>9 x DI</b>	<b>2 x DI</b>	4 x ID	3 x ID
	2.0 %	5 x DI	2 x DI	2 x DI	1 x DI
	0.5%	14 x DI	3 x DI		
	<b>1.0%</b>	<b>7 x DI</b>	<b>3 x DI</b>		
	2.0 %	4 x DI	2 x DI		
	0.5%	14 x DI	3 x DI		
	<b>1.0%</b>	<b>7 x DI</b>	<b>3 x DI</b>		
	2.0 %	4 x DI	2 x DI		
	0.5%	36 x DI	6 x DI		
	<b>1.0%</b>	<b>24 x DI</b>	<b>4 x DI</b>		
	2.0 %	12 x Di	3 x DI		
	0.5%	24 x DI	6 X DI	12 x DI	3 x DI
	<b>1.0%</b>	<b>17 x DI</b>	<b>4 x DI</b>	7 x D	3 x D
	2.0 %	9 x DI	3 x DI	2 x DI	2 X DI

## 4. Weld-In Stud Orientation

You must select the appropriate orientation for your stud based on the media, the conduit, and the model design of your deltaflow.

### 4.1. Gaseous Media

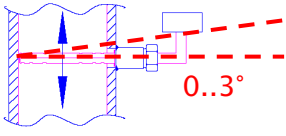
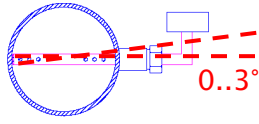
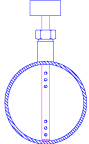
Installation Position	Illustration	Comment
Vertical conduit, connection head at right angle		The stud is installed in a horizontal position or with a slight decline (maximum 3°) toward the point of the probe. Leads to the differential pressure transducer are trailed upwards. This ensures that any condensation can run off without obstruction.
Horizontal conduit, connection head at right angle		The stud is installed in a horizontal position or with a slight decline (maximum 3°) toward the point of the probe. Leads to the differential pressure transducer are trailed upwards. This ensures that any condensation can run off without obstruction.
Horizontal conduit, straight connection head.		The probe is installed vertically from either the top or the bottom of the conduit, or at an angle of a maximum of +/- 30°. Leads to the differential pressure transducer are trailed upwards. This ensures that any condensation can run off without obstruction.

### 4.2. Liquid Media

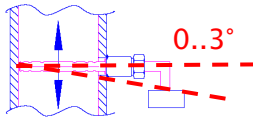
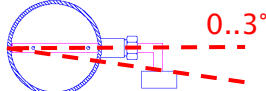
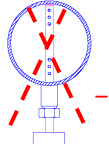
Installation Position	Illustration	Comment
Vertical conduit, connection head at right angle		The stud is installed in a horizontal position or with a slight incline (maximum 3°) toward the point of the probe. Leads to the differential pressure transducer are trailed downwards. This ensures that the deltaflow can be ventilated with no difficulties.
Horizontal conduit, connection head at right angle		The stud is installed in a horizontal position or with a slight incline (maximum 3°) toward the point of the probe. Leads to the differential pressure transducer are trailed downwards. This ensures that the deltaflow can be ventilated properly.
Horizontal conduit, straight connection head.		The probe is installed upside down, or at an angle of a maximum of +/- 30°. The leads to the differential pressure transducer are trailed downwards. Gas bubbles can escape from the deltaflow without obstruction.

### 4.3. Steam Media

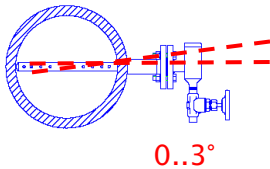
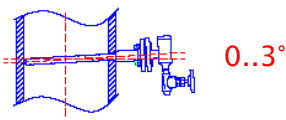
Installation Position	Illustration	Comment
Horizontal Conduit		The probe is installed horizontally or with a slight decline (max. 3°) toward the point of the probe. The leads to the dp transducer are trailed downwards. Excess condensation flows back into the conduit and evaporates there. When installing, it is very important to make sure that the condensation containers are aligned and level (use a spirit level)!
Vertical Conduit		The probe is installed horizontally or with a slight decline (maximum 3°) toward the point of the probe. The leads to the transducer are trailed downwards. Excess condensation flows back into the conduit and evaporates there. When installing, it is very important to make sure that the condensation containers are aligned and perfectly level (use a spirit level)!

## 5. Installing the Weld-in Stud

Your deltaflow purchase comes complete with an appropriate weld-in stud. **The dimensions of the weld-in stud have a significant impact on metering precision.** Please use the stud that came with your deltaflow and please do not alter the stud in any way! The standard height of the weld-in stud is 125 mm. For installations where insulation thicknesses are >100mm, special probes with extended studs are provided by systec. Please contact systec if there is any question regarding this equipment.

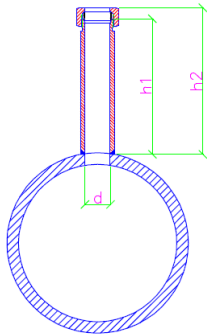

### Cutting Ring Stud

The standard height of the cutting ring stud h1 (without swivel nut) is 125mm, h2 (with swivel nut, after tightening approx. 137mm). Other stud heights are available from systec.

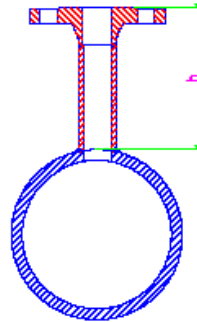

### Flange Stud

The standard height of the flange stud h is 125 mm. Other stud heights are available from systec.

To install the weld-in stud, please determine and mark the installation point, then bore a 28 mm hole (for deltaflow model DF25) or a 53.5mm hole (DF44) or a 60 mm hole (DF50) into the conduit. For DF12 see separate chapter 12. If your deltaflow includes an opposite support, determine the positioning of the opposite support and bore another hole into the opposite wall of the conduit. Directions for determining the position of the opposite support can be found below, under Item 6.

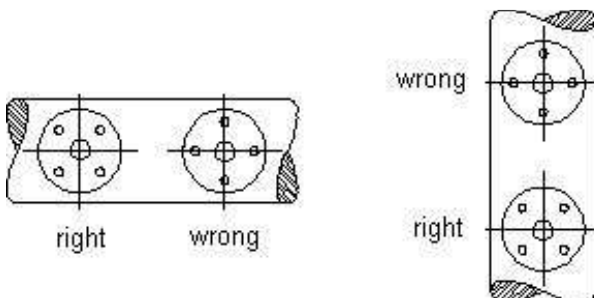

Flange holes for the weld-in stud must be positioned parallel to the direction of the conduit.

Remove all paint and rust in the area surrounding the welding site and select a welding filler appropriate to the material of the stud and the conduit material. The welding fillers recommended below are not mandatory. Please confirm your choice of an appropriate welding filler with your welding expert, or contact systec Controls.

### Recommended Welding Fillers (Böhler)

Conduit Material	Stud Material	WIG	Electrodes	Oxyacetylene
Carbon Steel (St 35.8)	Carbon Steel (ST35.8)	DMO-IG	Fox EV50	BW XII
Carbon Steel (St 35.8)	Stainless Steel (1.4571)	A7-A-IG	Fox A7-A-IG	-
Stainless Steel (1.4571)	Stainless Steel (1.4571)	SAS4-IG	Fox SAS4-IG	-

You will find a stamp imprinted on the stud identifying the material the stud is made of, or the material will be indicated in the sales confirmation. If you are unsure about the material of the stud, the conduit, or the welding filler, please consult your welding expert or contact us.

Tack-weld the weld-in stud to this location and adjust it carefully, considering the correct installation orientation and recommended slope. To be sure that the stud is positioned correctly, it is a good idea to temporarily install the probe into the stud once the stud has been tack-welded to the conduit. Please be sure to remove the probe before you finish welding the stud. The probe should extend all the way through the diameter of the conduit, and may even touch the opposite wall of the pipe (this is not true if an opposite support is being installed). If the probe is too short or too long, please re-measure the conduit (exterior diameter and wall thickness) and the stud (length), note the probe's serial number (DF...) and contact your sales agent or systec Controls directly before proceeding to install the equipment. Use a brush to remove any punk or tarnish, and take appropriate steps to protect both stud and conduit from rust.

## 6. Installing the Opposite support

Some deltaflow models are equipped with opposite supports; opposite supports are standard on DN 1000 and larger. The opposite support is an integral part of the product and must not be altered.

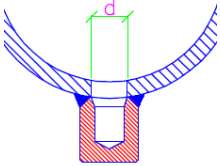

Standard opposite support for deltaflow DF25: In addition to the standard opposite support, there are several other optional designs. If you are not sure, note the serial number of your deltaflow and contact your agent or directly systemec Controls.

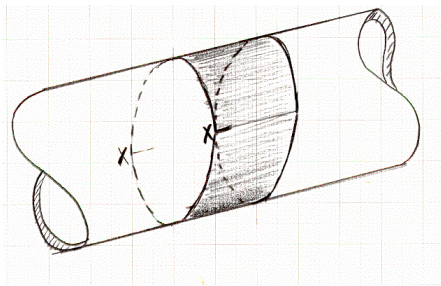

One way to determine the point on the conduit opposite the stud is to use a piece of writing paper. Without folding, wrap the paper around the pipe and position the overlap of the two edges at the center of the weld-in stud. Use a pencil to mark the point of overlap on the paper. Remove the paper from the pipe and fold the marked length (circumference) in half. Mark this halfway point as well. Put the paper back to the pipe in the previous position. Mark the halfway point on the conduit, where the opposite support will be installed. For the opposite support, drill a hole 28mm (for deltaflow model DF25) or 78mm (for deltaflow model DF50) in diameter into the conduit.

Remove all paint and rust in around the welding points and select a welding filler material appropriate to the opposite support and the conduit.

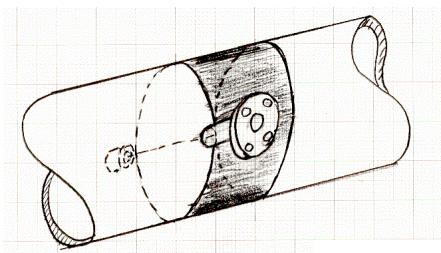

We recommend that you first tack-weld the stud into the conduit, adjust the positioning, and then temporarily install the deltaflow. Next plug the opposite support onto the deltaflow so you can be sure it is positioned correctly, and then carefully tack-weld the bearing onto the conduit. Finally, uninstall the deltaflow and weld the stud and opposite support firmly into place.

Gegenlager DF25/DF34/DF44  
Opposite Support D25/DF34/DF44

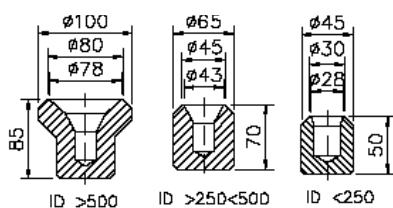

Gegenlager DF50 Seite 6 / Kapitel 6  
Opposite support DF50 Page 6 / Chapter 6

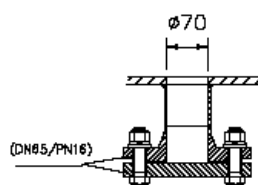

## 7. Installing Pulse Conduits / Connecting the Differential Pressure Transducer

On your deltaflow you will find a label indicating the flow direction and the polarity of the differential pressure connections. Please attach the + and - connections to your dp transducer as indicated on the label depending on the direction of your flow. There will be + and - indicators on the transducer as well.

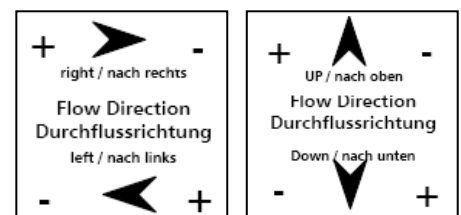

## 7.1. Steam Media

The deltaflow for steam comes equipped with condensation containers. The differential pressure is carried to the transmitter via a condensate column. When installing, be sure that the condensation containers are installed in a horizontal position (use a spirit level) and that the pulse conduits are installed with a steady decline toward the transmitter.

### Separate Mounting

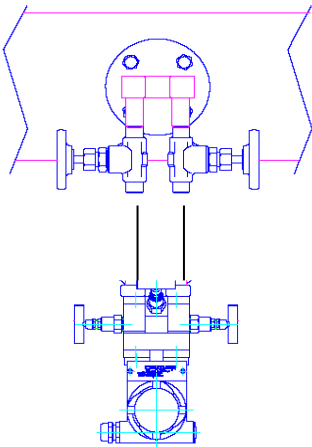

If the deltaflow is purchased without installation block or three-way manifold, the impulse conduits must be installed onsite. In this situation, the differential pressure transducer is generally installed in combination with a multi-directional valve assembly on a wall or mounting frame. The impulse conduits between the deltaflow and the dp transducer must maintain a consistent downward slope and should have an interior diameter of a minimum of 8mm. The length of the impulse conduits can be determined at will, but be sure to position the conduits close to each other and parallel in order to prevent differences

### Direct Mounting

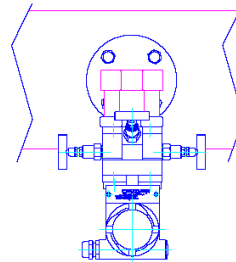

If the deltaflow is purchased with an installation block and multi-directional valve assembly, the dp transducer can be mounted directly to the probe and no additional conduits are necessary.

## 7.2. Liquid Media

When using the deltaflow for liquids, the differential pressure is carried to the dp transmitter through the liquid. Gas bubbles within the pulse conduits result in metering errors. For this reason, it is important to install and connect the dp transducer in such a way as to allow gas bubbles to rise to the conduit pipes.

### Separate Mounting

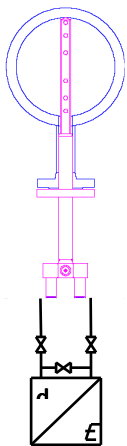

If the deltaflow is purchased without installation block or three-way manifold, the impulse conduits must be installed onsite. In this situation, the differential pressure transducer is generally installed in combination with a multi-directional valve assembly on a wall or mounting frame. The impulse conduits between the deltaflow and the dp transducer must maintain a consistent downward slope and should have an interior diameter of a minimum of 8mm. The length of the impulse conduits can be determined at will, but be sure to position the conduits close to each other and parallel in order to prevent differences in temperature and density between the two conduits.

### Direct Mounting

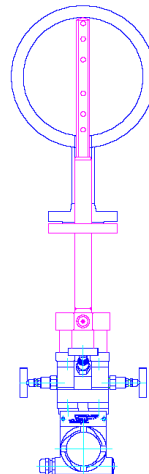

If the deltaflow is purchased with an installation block and multi-directional valve assembly, the dp transducer can be mounted directly to the probe and no additional conduits are necessary.

### 7.3. Gas Media

Condensates within your deltaflow can disrupt the metering of gasses. For this reason, it is important to connect the dp transducer in such a way as to allow condensation to drain freely toward the point of the probe.

#### Separate Mounting

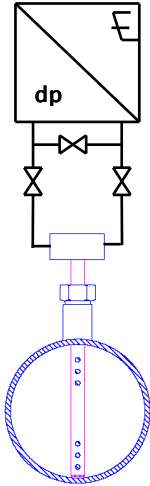

If the deltaflow is purchased without installation block or three-way manifold, the impulse conduits must be installed onsite. In this situation, the differential pressure transducer is generally installed in combination with a multi-directional valve assembly on a wall or mounting frame. The impulse conduits between the deltaflow and the dp transducer must maintain a consistent upward slope and should have an interior diameter of a minimum of 8mm. The length of the impulse conduits can be determined at will.

#### Direct Mounting

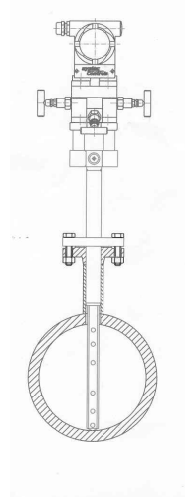

If the deltaflow is purchased with an installation block and multi-directional valve assembly, the dp transducer can be mounted directly to the probe and no additional conduits are necessary.

## 8. Splitting Range, Bi-directional, or Redundant—Multiple Transmitters for the deltaflow

For specific applications—such as metering flow in two directions (bi-directional), automatic split range for large flow metering ranges (Splitting Range), or multiple meterings (redundant)—deltaflow can be equipped with multiple transducers. This can be done using either direct mounting or separate mounting methods.

For automatic splitting range and redundant meterings, transducers with different sampling ranges are connected in parallel configuration. For bi-directional meterings, the + and - connections at the transducer need to be switched to compensate for the negative flow.

#### Separate Mounting (Gas)

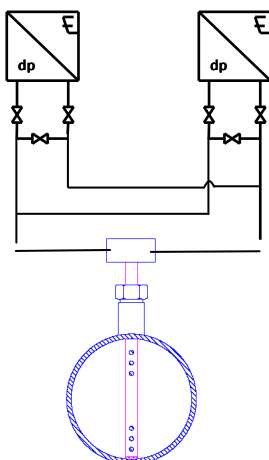

#### Direct Mounting (Liquid)

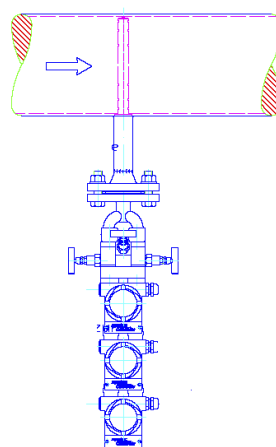

The direct mounting process can be made quick and easy by using the optional double oval flanges available from systemec. With these flanges, most dp transducers can simply be attached one below the other. (The example depicts 3 model SYS4422 transducers mounted in this way.)

## 9. Zero Point Calibration at Differential Pressure Transducer after Installation

In order to ensure the high degree of precision manifested by the deltaflow flow metering system under even the most minimal flow conditions, it is recommended that you perform a zero point calibration of the dp transducer after installation. Conditions during transportation, installation procedures, changes in temperature, and static pressure all have an influence on the zero point of your dp transducer, so it is best if you perform the zero point calibration after the conduit has been filled and when actual operational pressure is in effect.

It is also possible to check the zero point calibration on the dp transducer from time to time after the initial startup, and to adjust it as needed. Manufacturers of dp transducers recommend maintenance checks every two to five years. In metering conditions involving extremely small differential pressures (i.e. when metering flue gas flows) and wide variations in ambient temperatures (i.e. outdoor applications), it might be advisable to perform these maintenance checks more frequently.

### 9.1. Zero Point Calibration for Gas Media

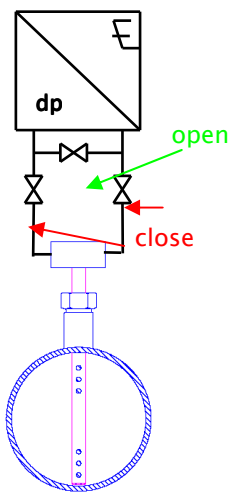

If you have installed a three or five-way manifold between your deltaflow and your dp transducer, then close both of the process valves (outer) and then open the bypass valve (middle). This creates the physical balance between + and -, and the differential pressure is zeroed out.

If there is no three or five-way manifold in your setup, be sure that there is no flow present in your conduit before performing the calibration procedure. We recommend that you close off all valves leading into your conduit. If your system includes a primary shut-off, you can close it and then open both of the ventilation valves at the transmitter. Both sides of the dp transducer are thus depressurized against the ambient environment, and the differential pressure is zeroed out.

Finally, perform a zero point calibration at your transmitter. You should find detailed instructions for this procedure in your transmitter documentation. On most transmitters you will find a button, a magnetic switch, or a potentiometer labeled "ZERO" which will allow you to perform the calibration. In some cases it may be necessary to attach an amperemeter to the outlet path of your dp transducer in order to monitor the calibration.

Many dp transmitters include a display for monitoring purposes. Some models of transmitters are even equipped with a calibration mode to adjust for factors related to the installation situation as well as a separate calibration mode for the zero point. Please refer to your transmitter documentation for details.

### 9.2. Zero Point Calibration for Liquid and Steam Media

If you are metering flows in liquid or in steam, you must be sure that your deltaflow is completely filled with the liquid or the condensate before performing the zero point calibration. If the deltaflow is not completely full (it is 100% ventilated=there is 0% air remaining in the meter), the zero point calibration will be flawed.

To ventilate, open all shut-offs between the deltaflow and the transmitters (except the bypass). If care was taken during installation and pipe assembly to ensure that the probe was installed with a steady decline, the deltaflow will eventually ventilate itself automatically when used in a full conduit. For metering liquids, allow approximately one hour for this to happen; for steam applications, allow approximately 2 hours.

If the conduit is not completely full, or if you do not want to wait so long, you can also fill the deltaflow manually. To do this, remove the ventilation screws at the dp transducers and force the medium through the transmitters upwards into the conduit.

If you have installed a three or five-way manifold between the deltaflow and the dp transducer, then close both of the process valves (outer) and open the bypass valve (center). This creates the physical balance between + and -, and the differential pressure is zeroed out.

If there is no three or five-way manifold in your setup, be sure that there is no flow present in your conduit before performing the calibration procedure. We recommend that you close off all valves leading into your conduit.

Finally, perform a zero point calibration at your transmitter. You should find detailed instructions for this procedure in your transmitter documentation. On most transmitters you will find a button, a magnetic switch, or a potentiometer labeled “ZERO” which will allow you to perform the calibration. In some cases it may be necessary to attach an amperemeter to the outlet path of your dp transducer in order to monitor the calibration. Many dp transmitters include a display for monitoring purposes. Some models of transmitters are even equipped with a calibration mode to adjust for factors related to the installation situation as well as a separate calibration mode for the zero point. Please refer to your transmitter documentation for details.

## 10. Additional Tips for Installing the DF25–Quicklock

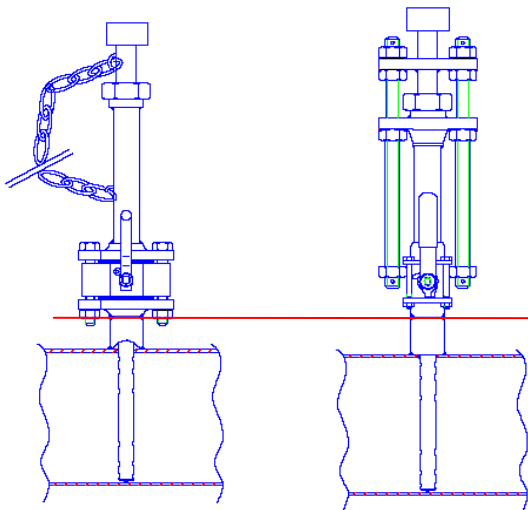

The DF25 Quiklock is available in two models: with flanged ball fittings or with weld-in ball fittings. For either model, the weld-in studs should be removed from the rest of the probe before installation and should be welded in separately. Please take note of the issues discussed above in the section “Installing the Weld-in Stud.”

Detach the studs here  
before installing

## 11. Additional Tips for Installing the DF8 / DF10 or DF12/DF25 with spool pieces

The DF8 and the DF10 consist of spool pieces in which the probe (or in some cases the orifice) is purchased preinstalled. DF12 and DF25 are optionally available with spool piece.



The DF10 and the DF8 but also the DF12 and DF25 (available with spool pieces as an option) are available with various connection options for tying into your conduit system, such as flanges, weld-on ends, or threaded connections.

The correct orientation of the probe or the orifice depends on the configuration of the dp connections and should be easy to determine visually. When determining the correct orientation of the sampling range, please follow the same instructions as were given in the section “Weld-in Stud. Orientation” above. It is as vital for the DF8 and the DF10 as it is for the DF12/DF25 that there is proper ventilation or the drainage of condensates.

## 12. Additional Tips for using DF12 (without spool piece)

The deltaflow DF12 is available with spool piece (see chapter 11) as well as “stand-alone” probe. In that case the DF12 can be mounted using flange or cut ring stud or can be welded into the pipe directly. Please check following drawings for proper installation

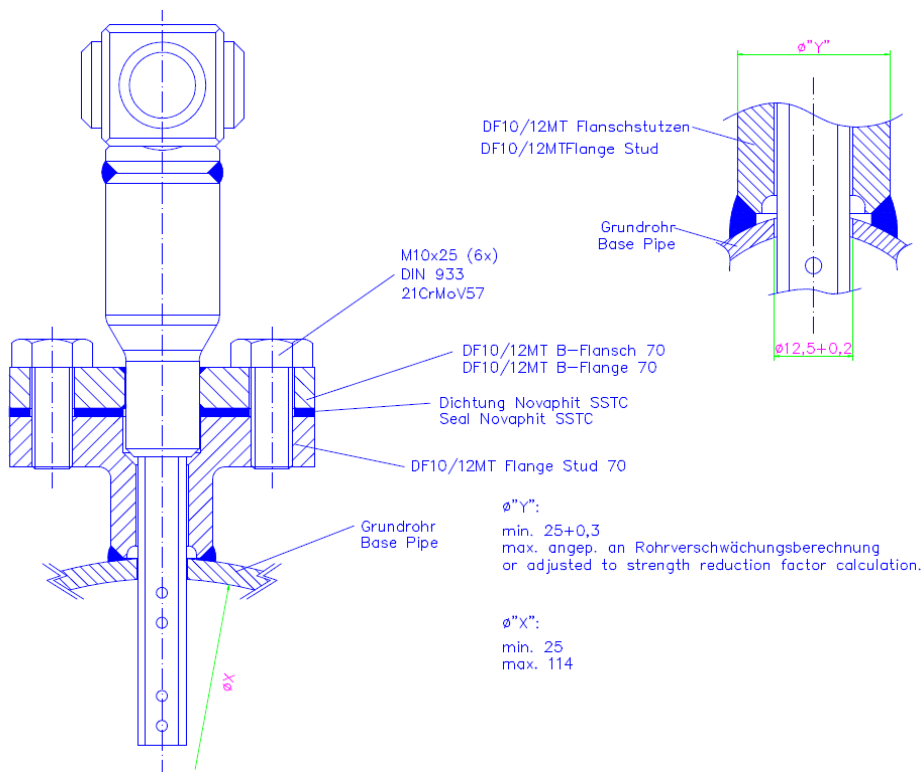

DF12 Flange-type

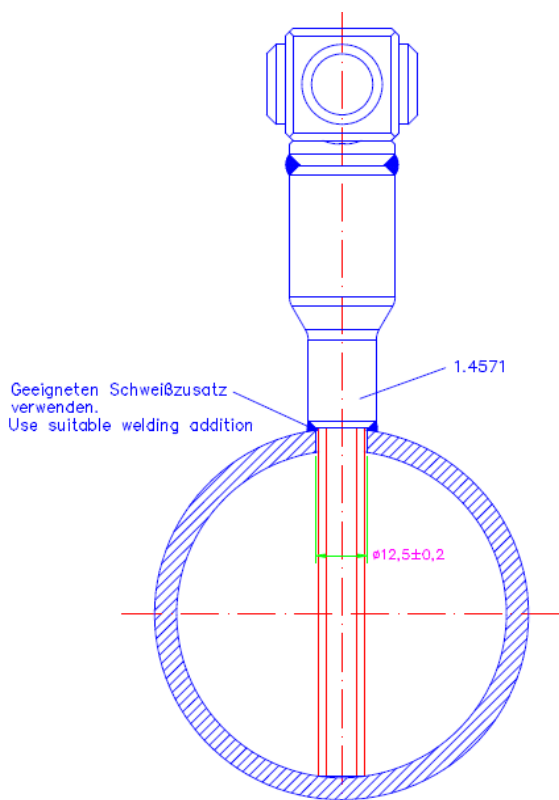

DF12 weld-in type

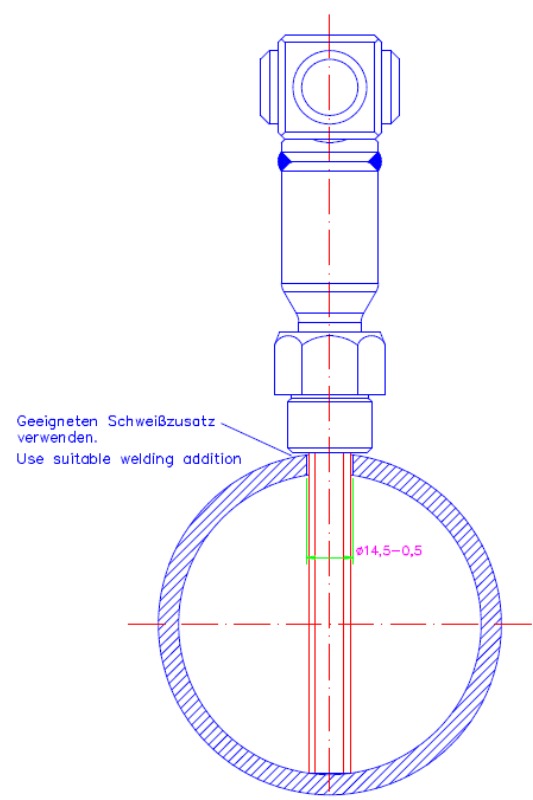

DF12 with cut-ring stud

### 13. Additional Tips for Using the LSP1 Air Flushing System



The deltaflow is especially resistant to dirty conditions. When metering media that are particularly high in particulate content, however, it may become necessary to perform periodic cleanings of the deltaflow. We recommend using the LSP1 Air Flushing System for this purpose. The LSP is installed between the deltaflow and the dp transducer and is supplied with auxiliary power and compressed air. The LSP is configured to use the compressed air to automatically “flush” out the deltaflow unit. This ensures the continuous, maintenance-free functionality of the deltaflow even under extreme conditions. Further detailed information is available in the LSP1 spec sheets.

### 14. Integrated Pressure and Temperature Sensors

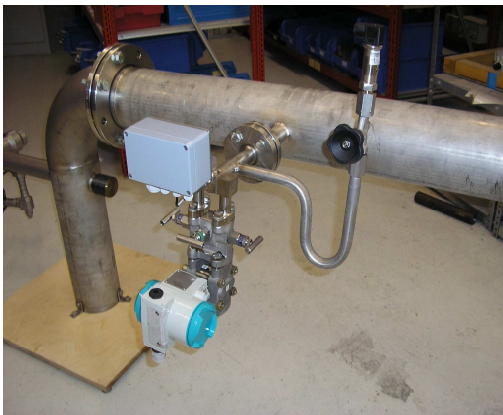

If desired, the deltaflow can be equipped with optional integrated pressure and temperature sensors and a proper connection box (for easy wiring)

Temperature is measured either by a miniature PT100 resistance thermometer or a Type K thermocouple. These are located in a sealed immersion sleeve inside the deltaflow and can be removed under pressure for testing or replacement purposes. To do this, the locknut must be completely opened, and the element can then be withdrawn. Any replacement element must be exactly the same length as the original element and its exterior diameter may measure no more than 2 mm. Please use an appropriate lubricant

material for insertion, such as copper paste. Integrated temperature measurement is available with and without transducer. If your deltaflow is equipped with a temperature transducer, please take time to become familiar with its description.

Pressure is measured by means of a G ½” stud with counterrotated threads located on the stud; for steam it is attached to a siphon and, if desired, an optional Manometer shut-off valve. Insert the sealing gaskets and screw the transducer into the stud. A connection diagram for the pressure transducer is included in the transducer package. systemec generally supplies absolute pressure transducers (0..1.6bara) for sampling ranges near the ambient pressure and gauge pressure transducers for higher pressures. Please refer to the equipment label or the sales confirmation document—the pressure range should be indicated on both of these.

Pre-installed pressure or differential pressure transducers must be tested for integrity after installation. Jostling during transportation can result in leaks or other compromises of integrity. Please retighten any joints that may have become loosened.

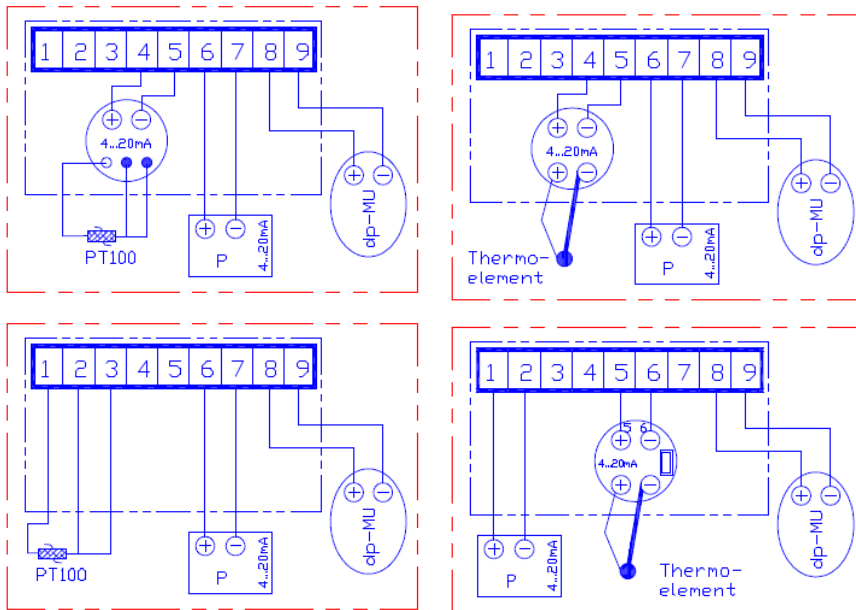

Wiring (in connection box) for integrated pressure transmitter and PT100-temperature sensor with transmitter (first picture) or without transmitter (second picture)

Examples for wiring (in connection box) for integrated pressure transmitter and temperature sensor (thermocouple Type K) with transmitter

## 15. Iceproofing / Weatherproof Housing

Important! Freezing can result in measurement errors and can damage the cells of differential pressure transducers. If the probe is to be installed out-of-doors, it may be necessary to provide some sort of heating unit or a weatherproof housing to ensure that temperatures do not fall below freezing. Please ask us.

If you use a deltaflow with a weatherproof box, please pay attention to the connection diagram included in the package. All sealing surfaces and threaded connections must be checked for leaks after installation and must be re-tightened if necessary.

## 16. Maintenance

If the deltaflow is used in media with pollution levels ranging from mild to normal, it will continue to function without any maintenance at all. When the deltaflow is used in applications containing especially high levels of pollution, we recommend using the LSP1 air flushing system. If you are unsure, please ask your dealer or contact systemec Controls.

## 17. Troubleshooting

The sections below contain a few tips for troubleshooting. We are happy to help you with any difficulties you may encounter—please take advantage of our support services.

### There is no display on my metering system.

- Has the primary shut-off been opened?
- Is the dp transducer correctly connected to the electrical source?
- Is the dp transducer correctly connected mechanically? (Refer to the “Installing Pulse Conduits / Connecting the Differential Pressure Transducer” section above.)
- Does the dp transducer register  $>4\text{mA}$ ? If yes, then check your electrical evaluation equipment.

### My metering system comes up with values that are too high or too low:

- Has the necessary straight inlet path been provided? (Refer to “Selecting an Appropriate Sampling Site” chapter.)
- Is the orientation of the weld-in stud correct? (Refer to “Weld-in Stud Orientation” chapter.)
- Are the construction dimensions of the weld-in stud correct? (Refer to “Installing the Weld-in Stud” chapter.)
- Is the transducer correctly calibrated?
- Do the conduit dimensions correspond exactly to the label on your deltaflow?
- Are the calculations for your deltaflow correct (deltacalc calculation sheet)? You can download our calculation program from our web page free of charge.
- Does the characteristic curve of the dp transducer correspond to the evaluation (mathematical root extraction)?
- Have obstructions been installed into the conduit upstream from your deltaflow?
- Did calculations compensate for ventilation and/or condensation draw during impulse conduit installation?
- Are differential pressure, pressure, and temperature calculated correctly in the evaluation software?
- Was a zero-point calibration performed at the dp transducer? (Refer to “Zero Point Calibration at the dp Transformer After Installation” chapter)

### My deltaflow does not fit into the conduit:

- Has the right seal been included?
- Do the dimensions of the conduit correspond exactly to the sizes listed on your deltaflow label?
- Does the weld-in stud have the correct dimensions? (Standard dimensions for flange studs are 125mm high above the pipe wall; other studs are available in customized sizes.)
- Did you reach the opposite support with your deltaflow (opposite support is not standard equipment)?

## 18. Additional Information

Additional reports and brochures can be obtained through your sales representative or directly from systemec Controls. They can also be downloaded free of charge from our website. You will find additional information about the deltaflow, as well as other pertinent information, in the following documents:

- deltaflow Data sheets
- deltaflow Calculation Basics
- deltaflow Brochure
- deltacalc Evaluation Software

## 19. Questions?

No one knows the deltaflow better than we do! Take advantage of our expertise—we are happy to help you. We have a network of associates in our field sales staff within Germany, and sales representatives in many other countries who stand ready to assist you. To find systemec representatives in your area, please consult our web page:

<http://www.systemec-controls.de>



Or simply call our headquarters in Puchheim (Germany):

**systemec Controls Hotline:**

**+49-(0)89 – 80 90 6 – 108**

## 20. Flow meters made by systemec

systemec Controls offers a wide range of precise flow meters made in Germany. The table below gives you some examples. Please visit us at [www.systemec-controls.de](http://www.systemec-controls.de) to get information about our full range of flow meters.

	<p><b>deltaWaveC: ultrasonic clamp-on flow meter for liquids</b></p> <p>Features</p> <ul style="list-style-type: none"> <li>• Pipe sizes: DN10 (1/3")...DN6000 (236")</li> <li>• Fluid temperature: -40...150°C</li> <li>• Media: All common liquids like water, waste water, oil...</li> <li>• Accuracy: Up to 1%</li> <li>• Principle: Ultrasonic time-of-flight</li> </ul> <p>Benefits</p> <ul style="list-style-type: none"> <li>+ Non-intrusive, hygienic measurement</li> <li>+ Integrated heat measurement as standard</li> <li>+ Quick and easy mounting under operation</li> <li>+ Quick-setup, large and convenient display</li> <li>+ Good value</li> </ul>
	<p><b>deltaflowC: Mass flow meter for gases</b></p> <p>Features</p> <ul style="list-style-type: none"> <li>• Pipe sizes: DN20...DN6000 (and bigger)</li> <li>• Gas temperature: -80...250°C</li> <li>• Gas pressure: 10 bar</li> <li>• Accuracy: Class 2% and 4% available</li> <li>• Media: Gases, non-explosive</li> </ul> <p>Benefits</p> <ul style="list-style-type: none"> <li>+ Multivariable with pressure/temperature/dp-sensors</li> <li>+ 2 Analog outputs for mass flow and temperature or pressure</li> <li>+ Ultra-fast: Up to 4000 measurements per second</li> <li>+ Good value (starts at 780€)</li> </ul>
	<p><b>deltaflow: Averaging pitot tube</b></p> <p>Features</p> <ul style="list-style-type: none"> <li>• Pipe sizes: 1...15000mm (models DF8/DF12/DF25/DF44)</li> <li>• Pressure: 0...690bar</li> <li>• Media: Gas, Steam, Liquids</li> <li>• Temperatur: -200...1240°C</li> <li>• Ex / ATEX, PED certified</li> <li>• Integrated pressure / temperature sensors (optional)</li> </ul> <p>Benefits</p> <ul style="list-style-type: none"> <li>+ Precise measurement (&lt;1%)</li> <li>+ maintenance-free for most applications</li> <li>+ Very low pressure loss</li> <li>+ Drift-free measurement</li> </ul>

## Notes